

# DTS3.0 Demo System

## Car Audio System with the HMS9XC8032

It is the HMS91C8032(DTS3.0) Demo Board.

- Block Diagram of the Demo Board
- Flow Chart
- Demo Board Schematic

### Composition Functions.

- AM/FM Block
- TAPE Deck
- CD-Changer
- LCD Display / CLOCK / KEY Control

### Block Diagram of the Demo Board

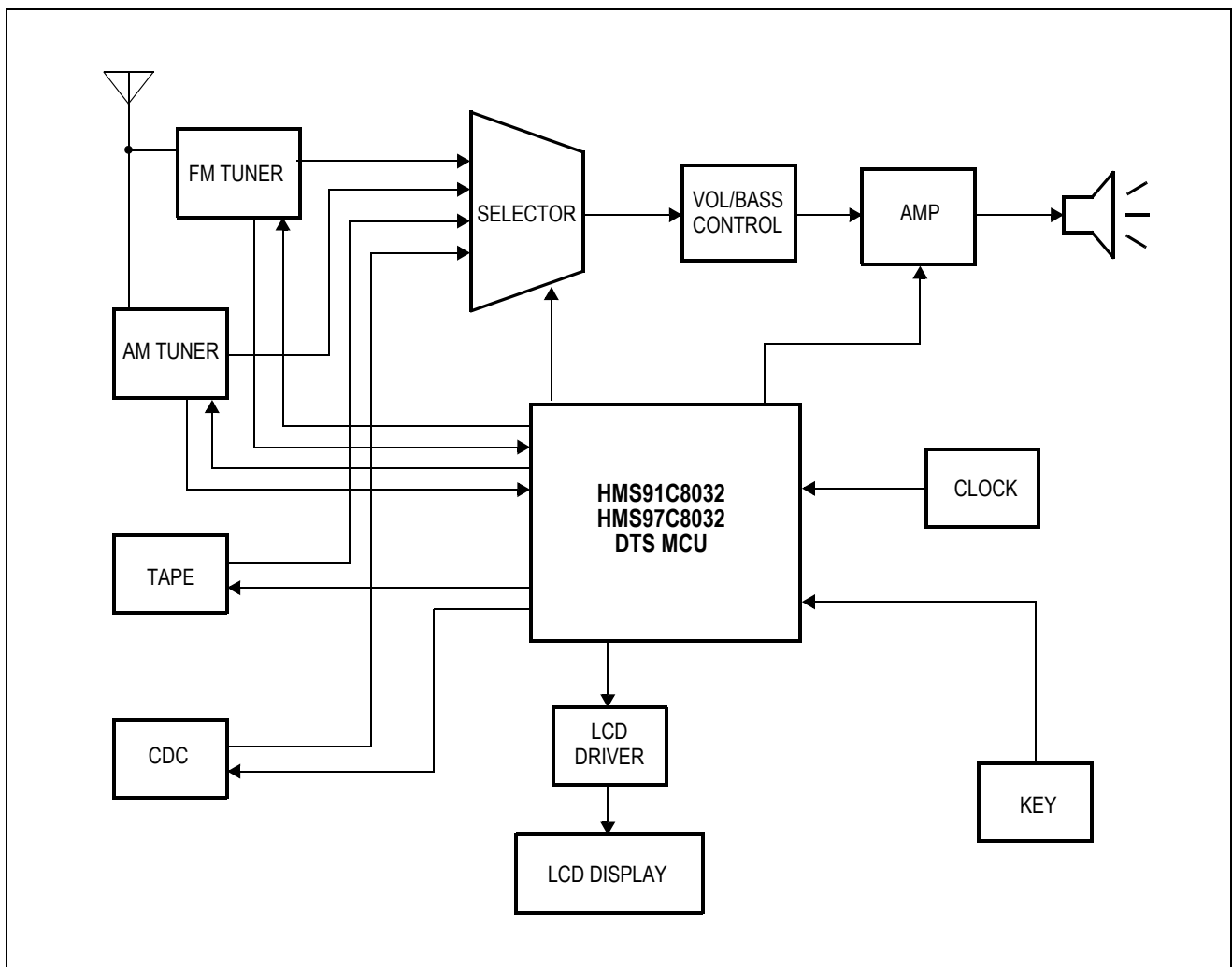

Figure 1. Car Audio System Block Diagram

Flow Chart

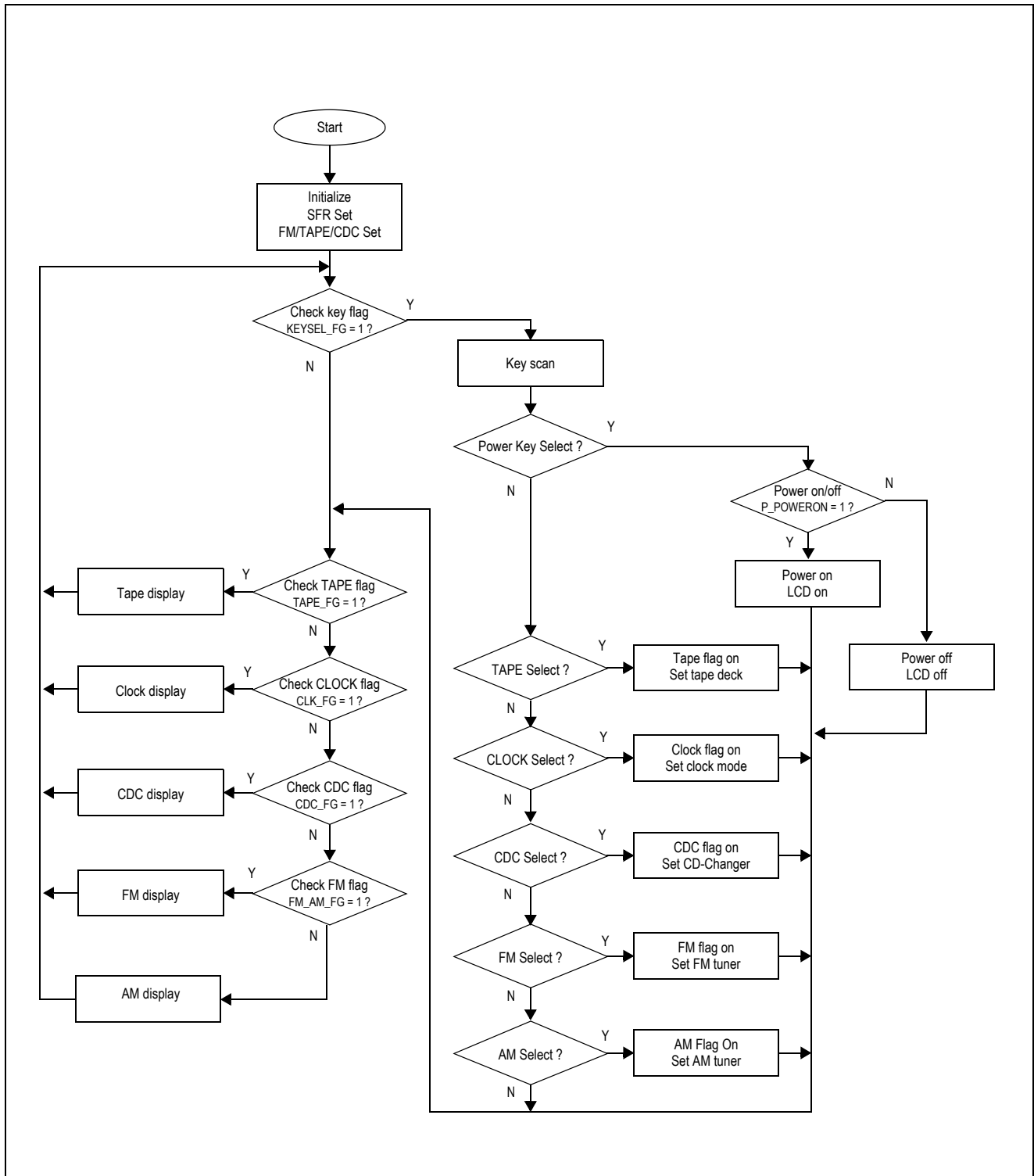

Figure 2. Car Audio System Flow Chart

Demo Board Schematic

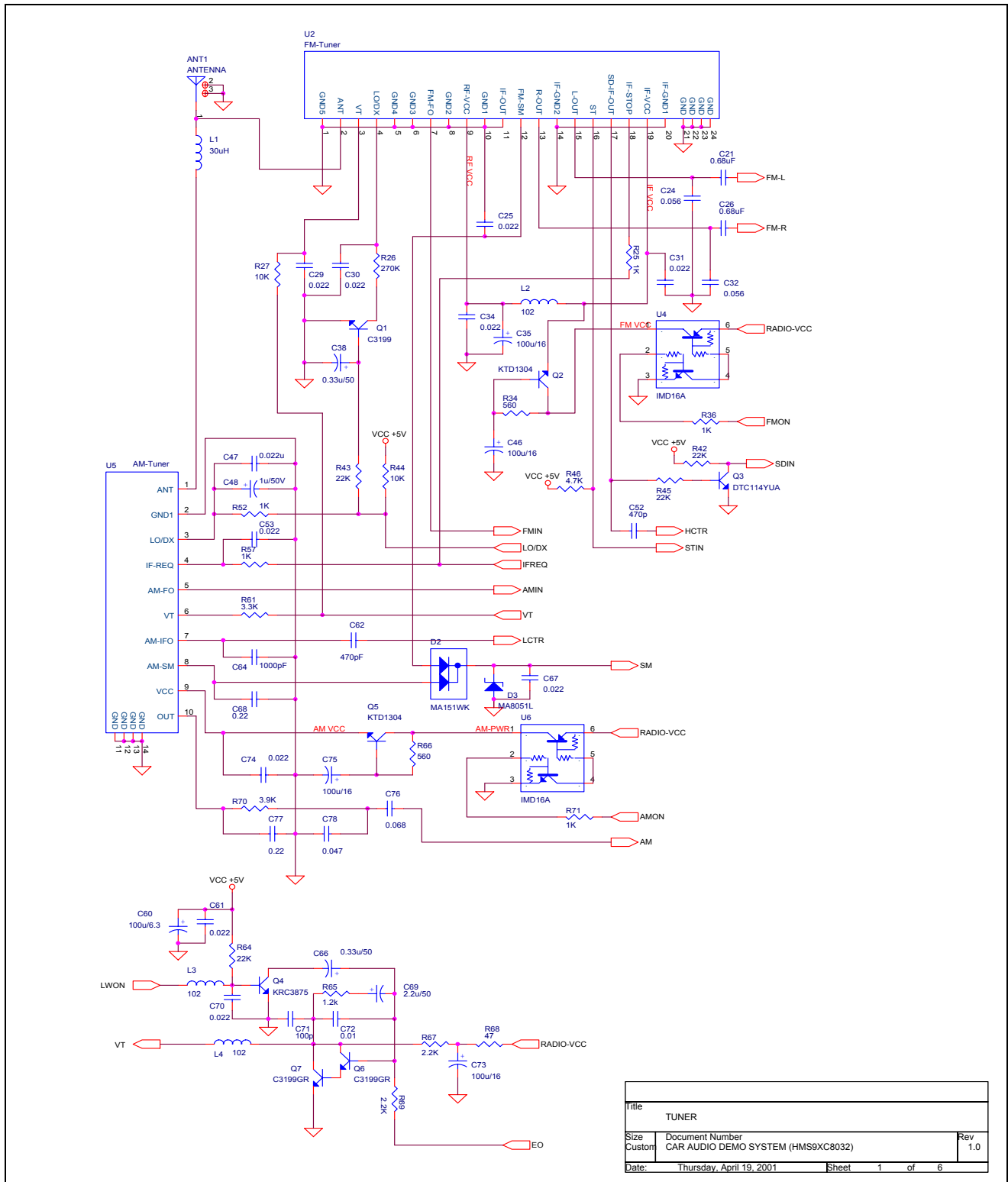
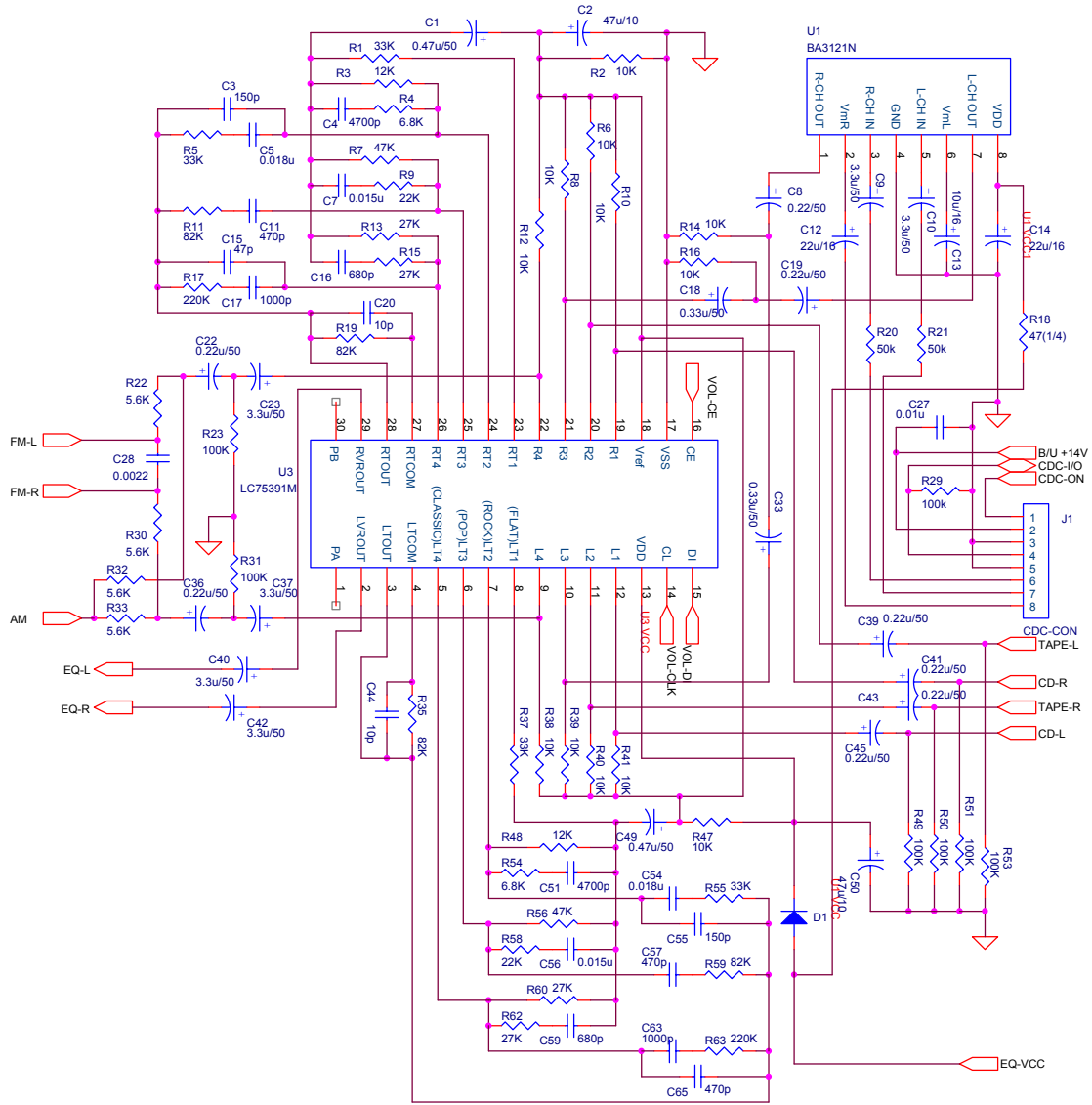

Figure 3. Tuner of Car Audio System



Title		
SELECTOR		
Size	Document Number	Rev
Custom	CAR AUDIO DEMO SYSTEM (HMS9XC8032)	1.0
Date:	Thursday, April 19, 2001	Sheet 2 of 6

Figure 4. Selector of Car Audio System

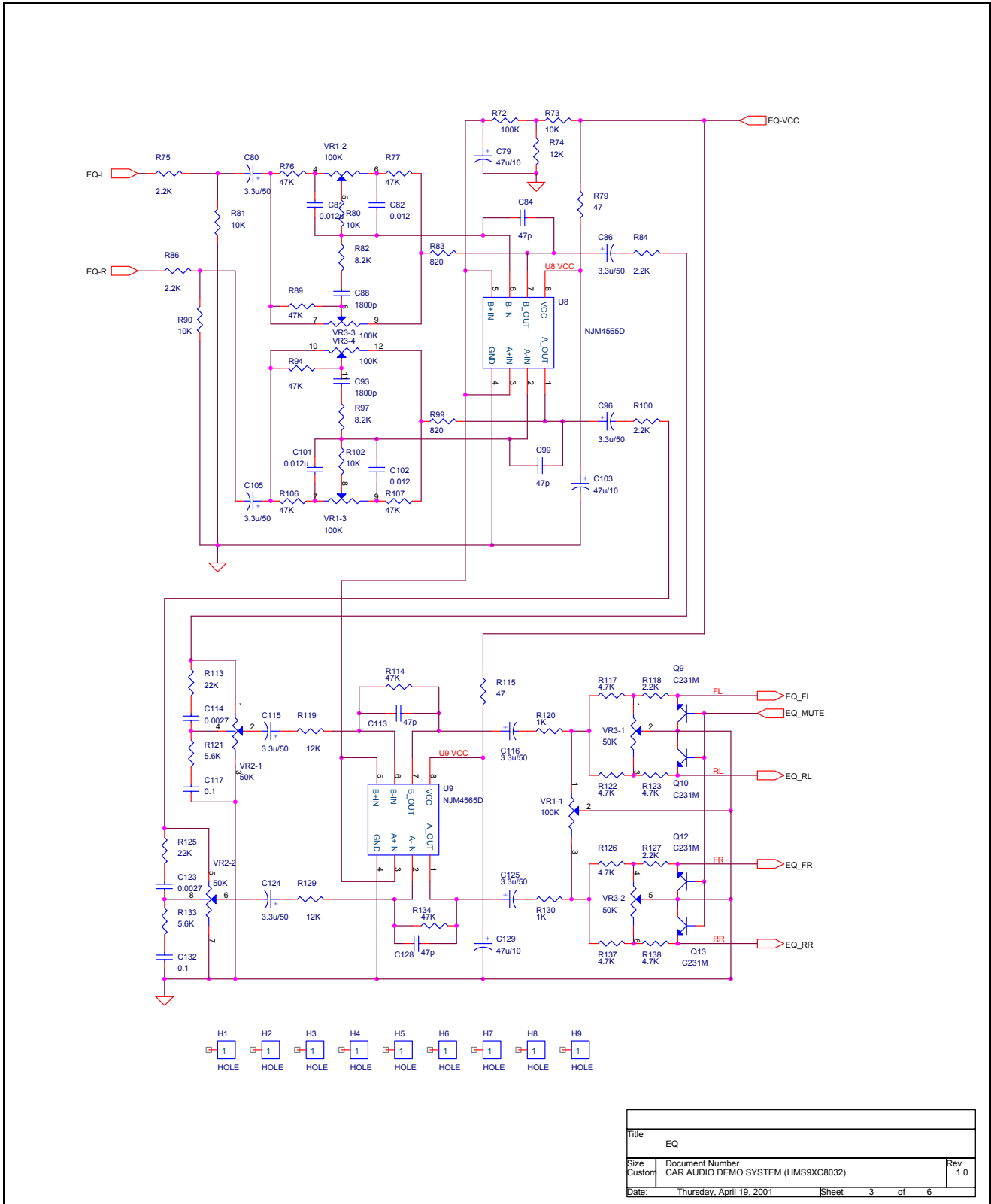

Figure 5. EQ of Car Audio System

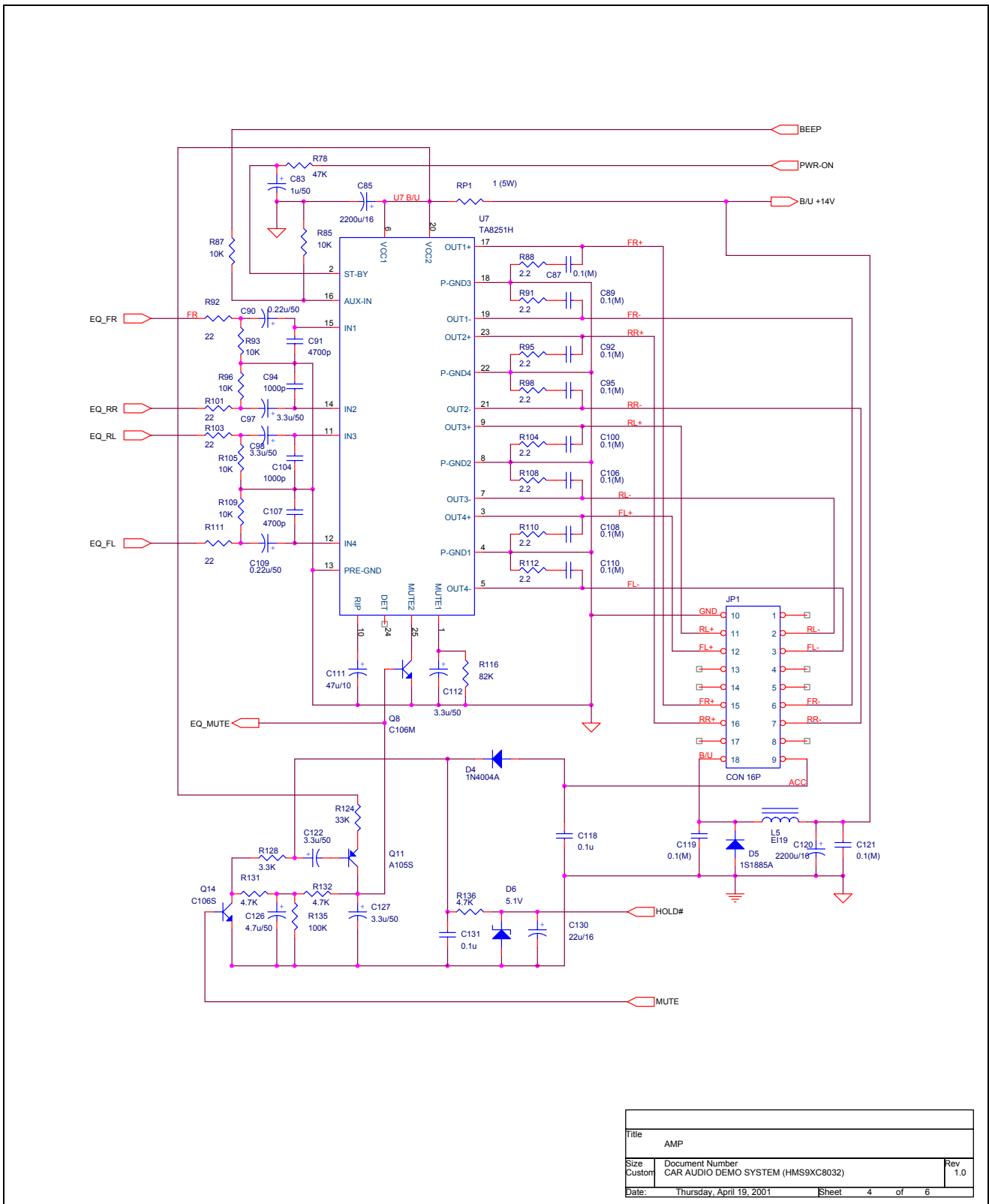

Figure 6. AMP of Car Audio System

Title			AMP
Size	Document Number	Rev	
Custom	CAR AUDIO DEMO SYSTEM (HMS9XC8032)	1.0	
Date:	Thursday, April 19, 2001	Sheet	4 of 6

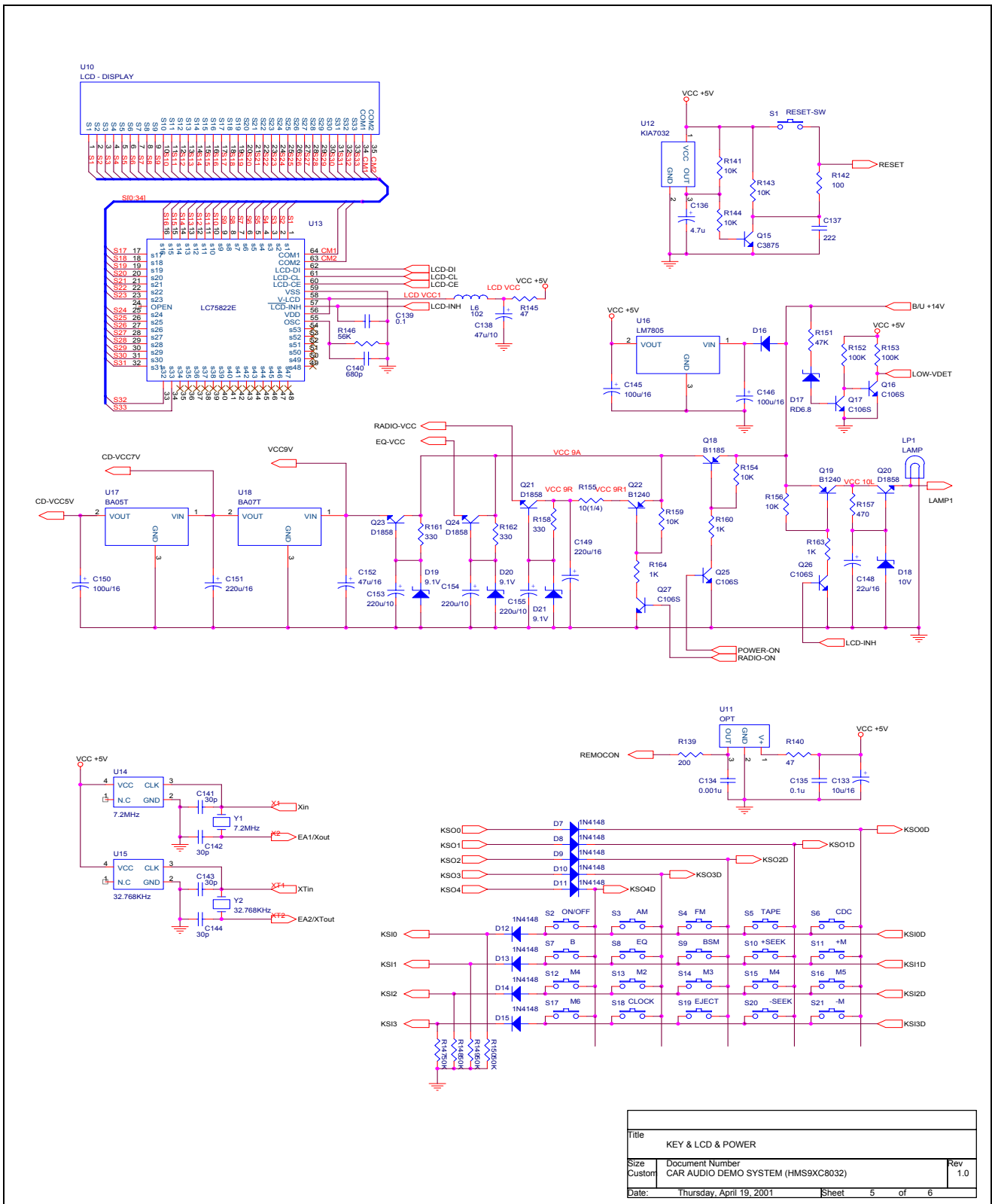

Figure 7. Tuner of Car Audio System

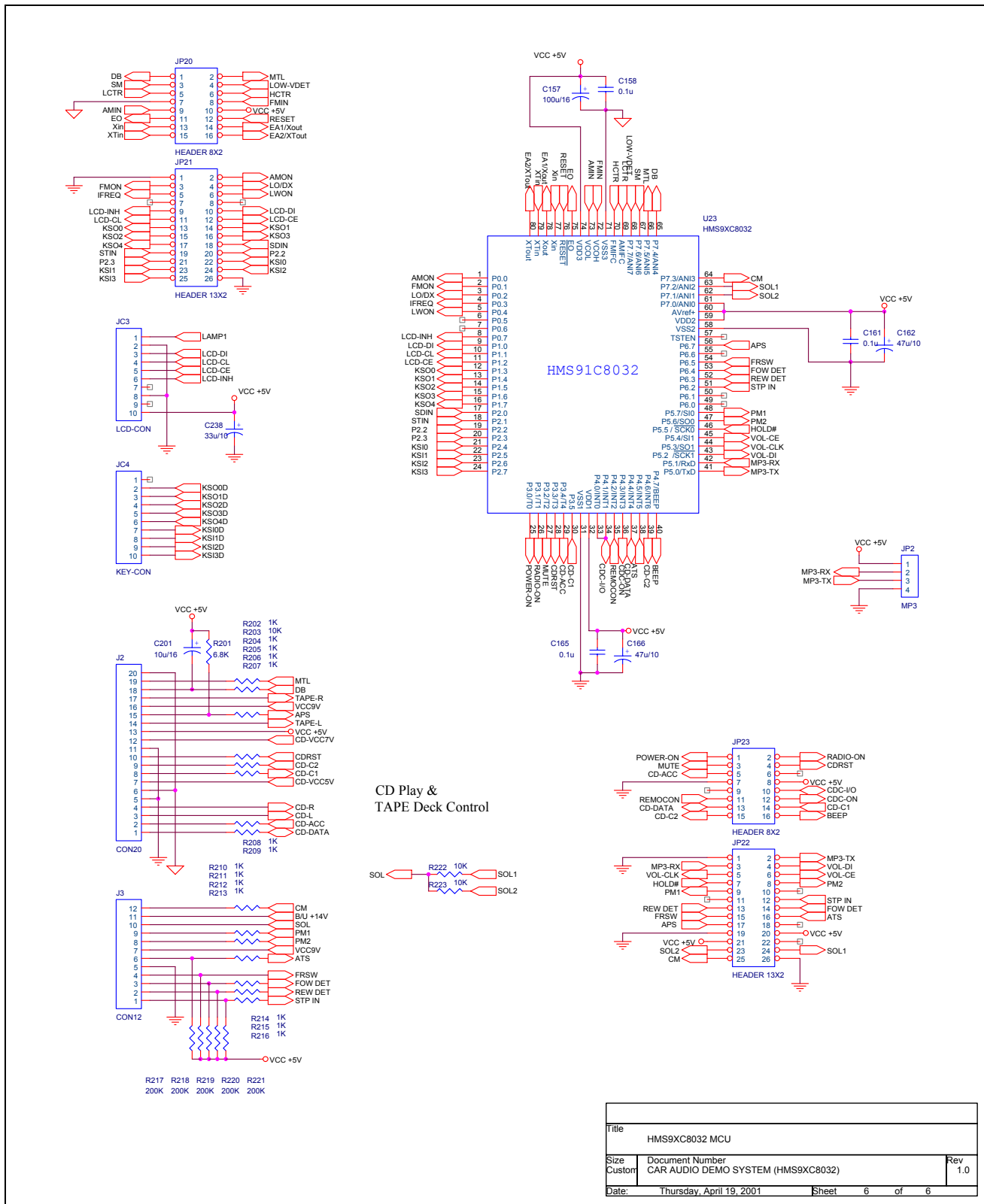

Figure 8. MCU of Car Audio System

Title		
HMS9XC8032 MCU		
Size	Document Number	Rev
Custom	CAR AUDIO DEMO SYSTEM (HMS9XC8032)	1.0
Date:	Thursday, April 19, 2001	Sheet 6 of 6