

HMS91C8232 Demo System

Car Audio System with the HMS91C8232/HMS97C8232

It is the HMS91C8232(DTS4.0) Demo Board.

- Block Diagram of the Demo Board
- Flow Chart
- Demo Board Schematic

Composition Functions.

- AM/FM Block
- CD-Changer
- LCD Display / CLOCK / KEY Control

Block Diagram of the Demo Board

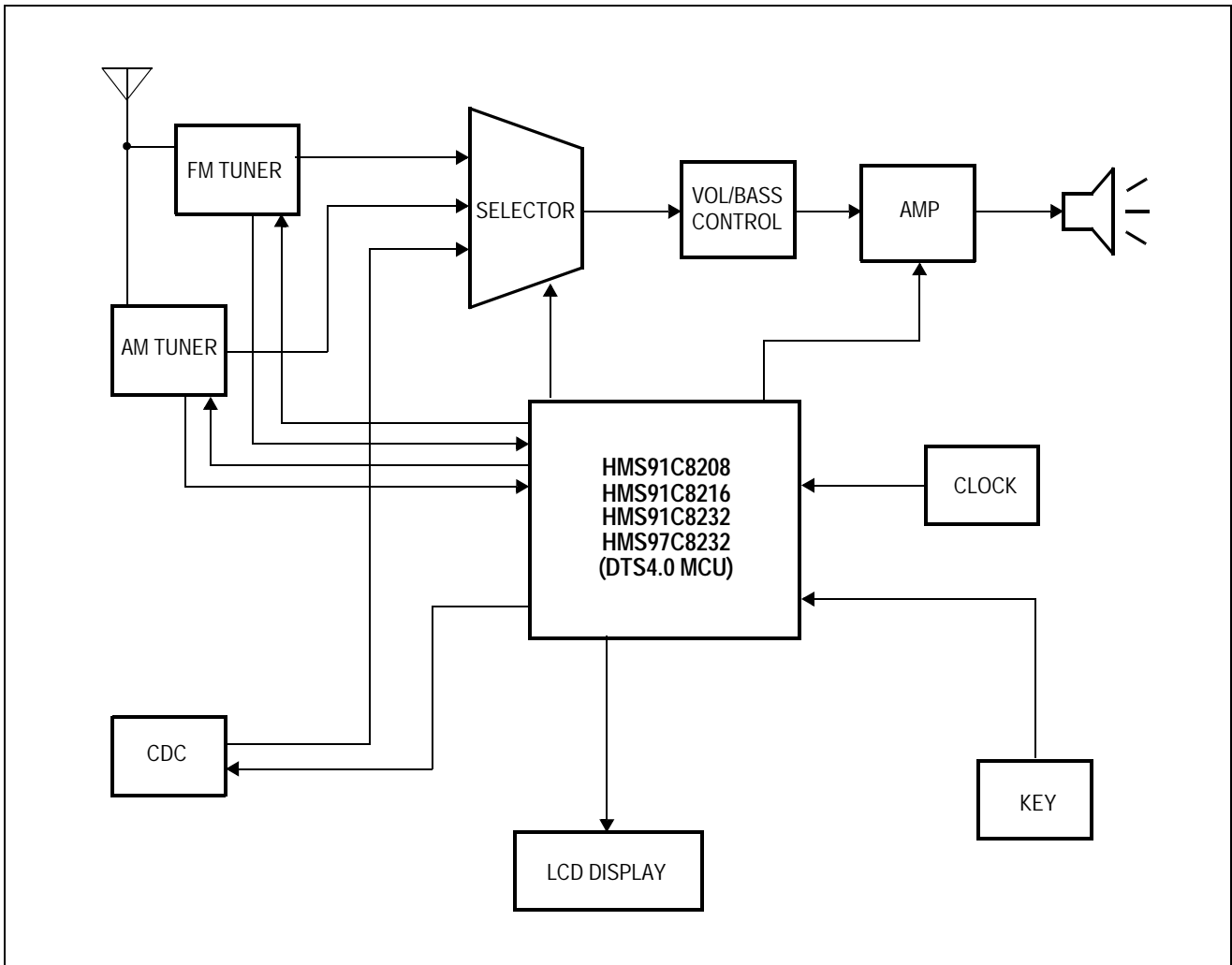

Figure 1. Block Diagram of Car Audio System

Flow Chart

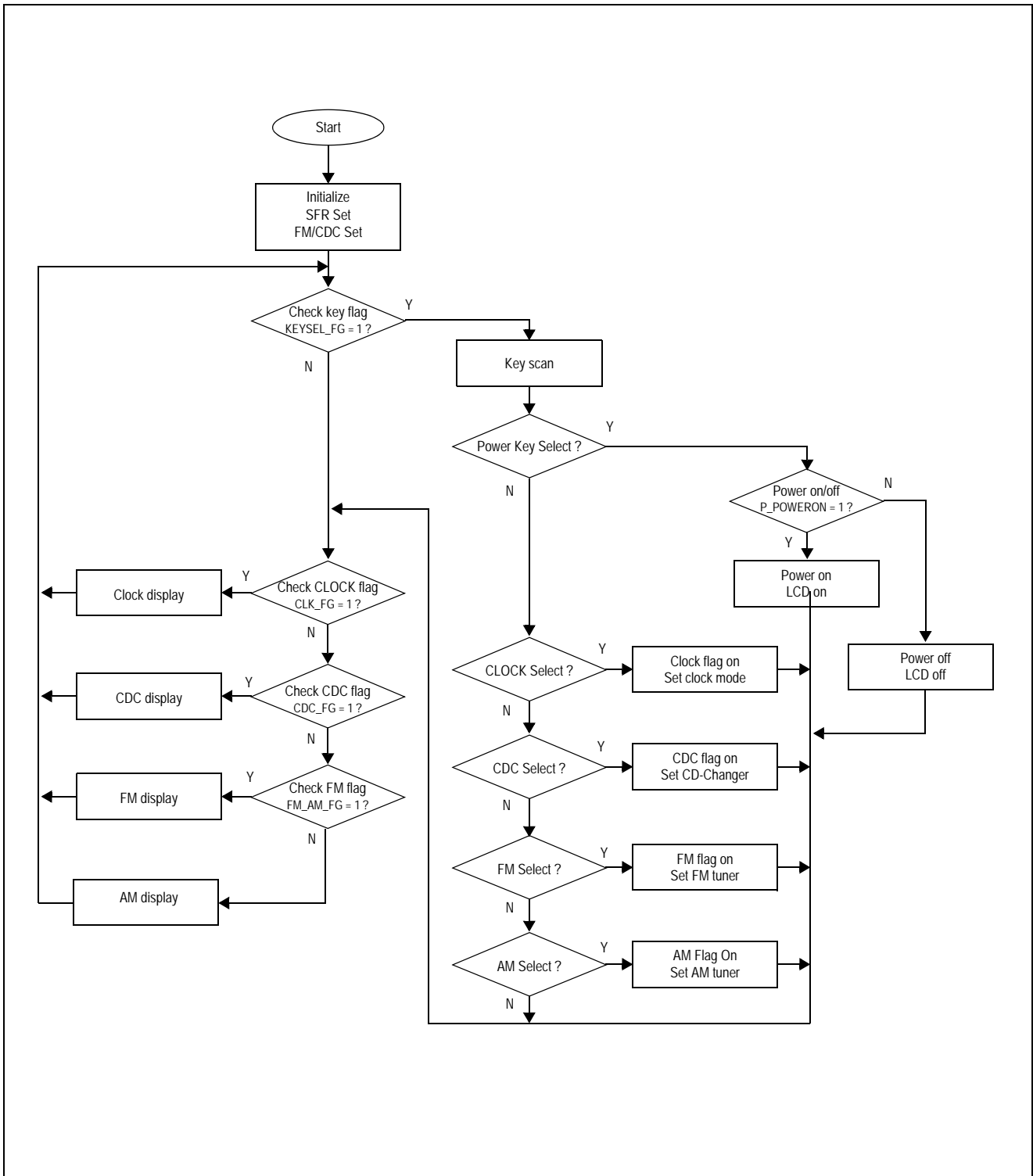

Figure 2. Flow Chart of Car Audio System

Demo Board Schematic

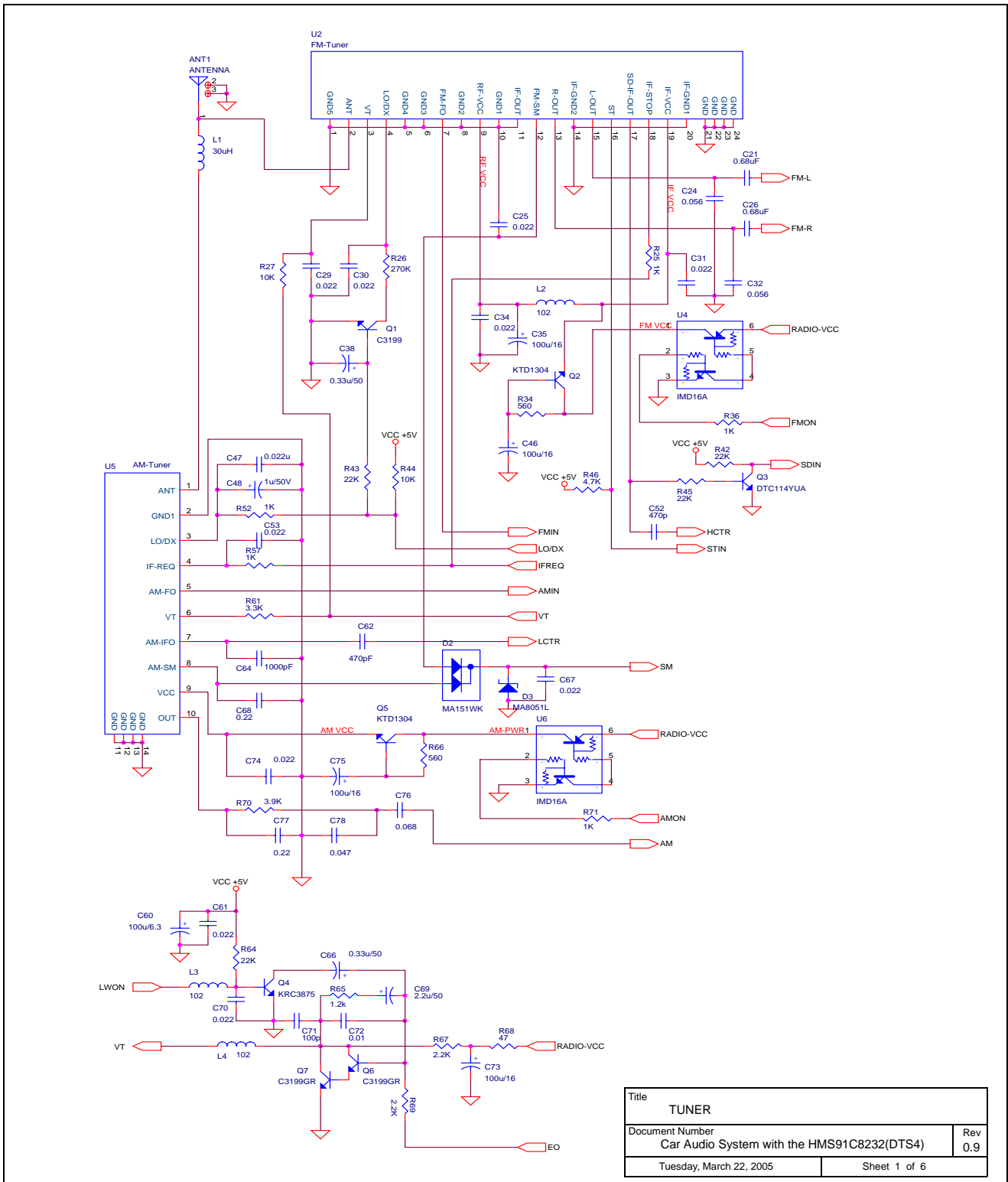

Figure 3. Tuner of Car Audio System

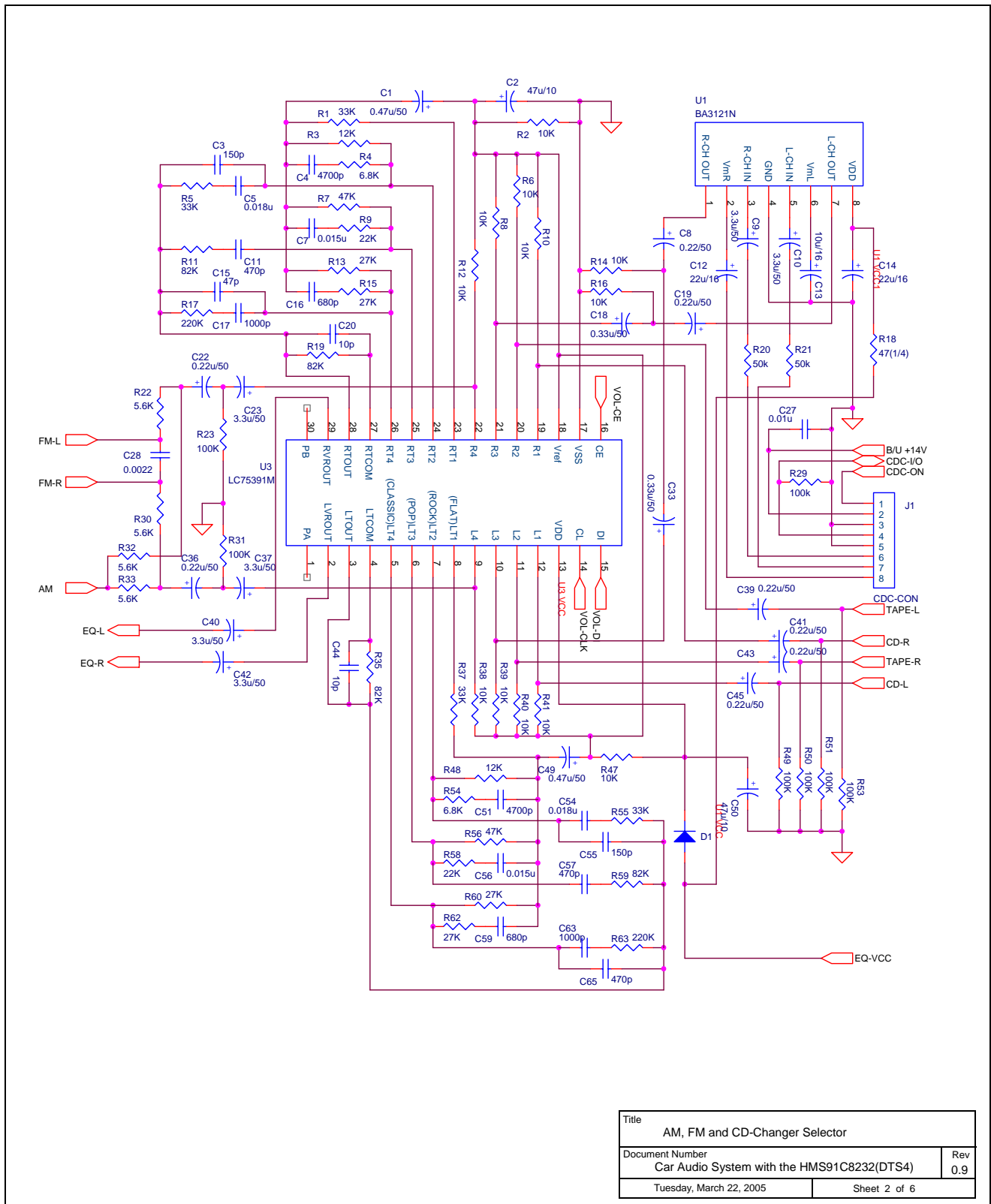

Figure 4. Selector of Car Audio System

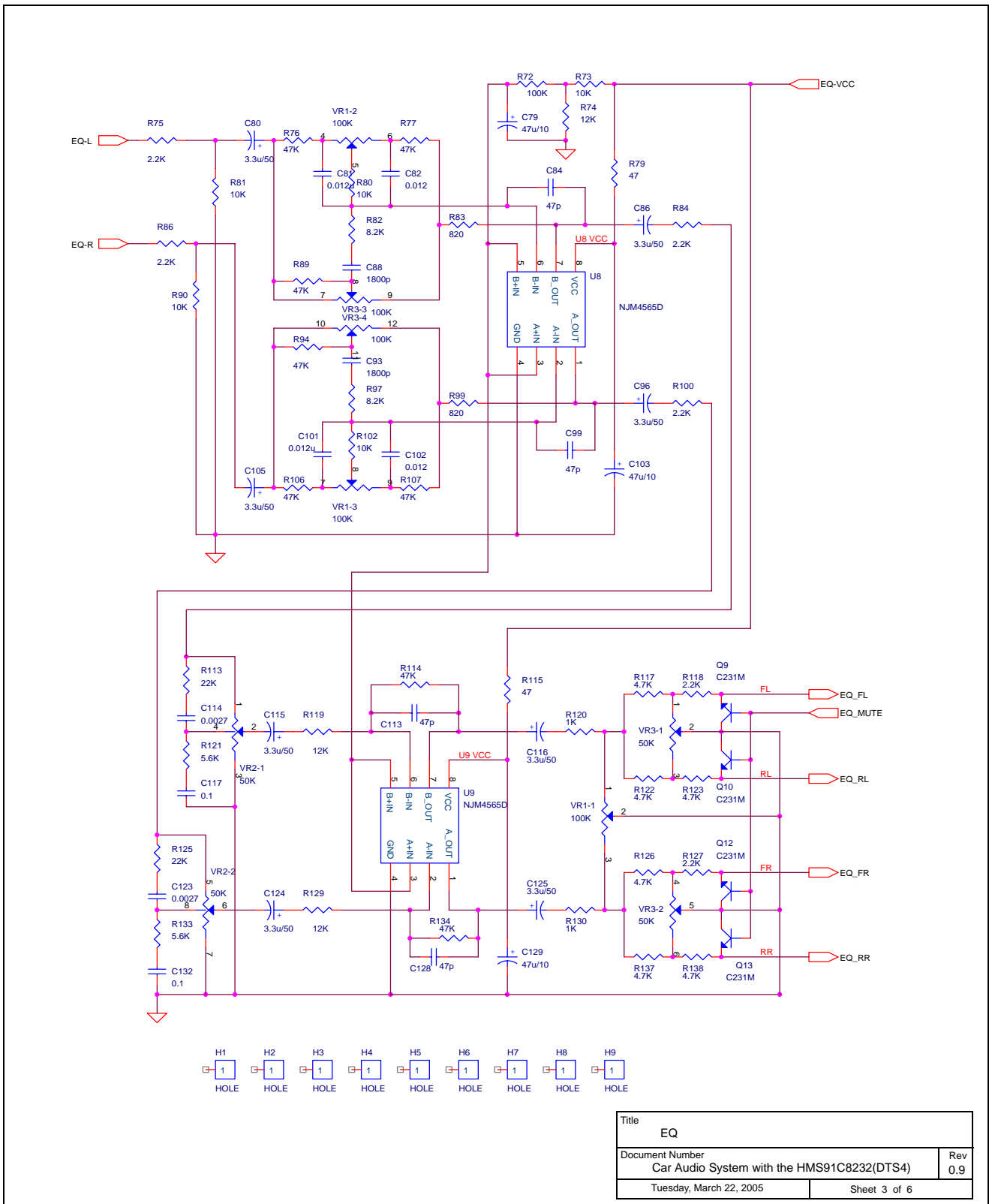

Figure 5. EQ of Car Audio System

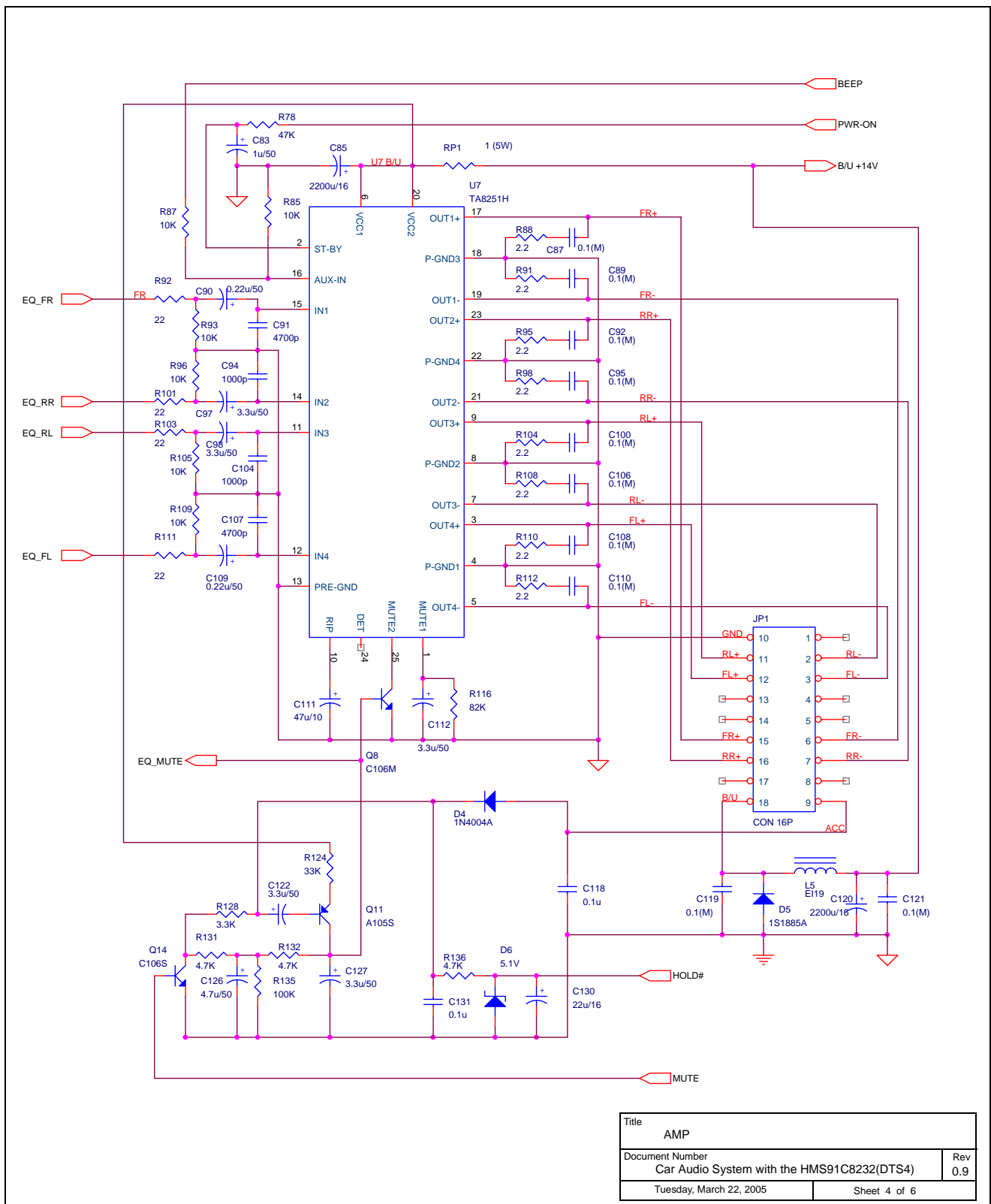
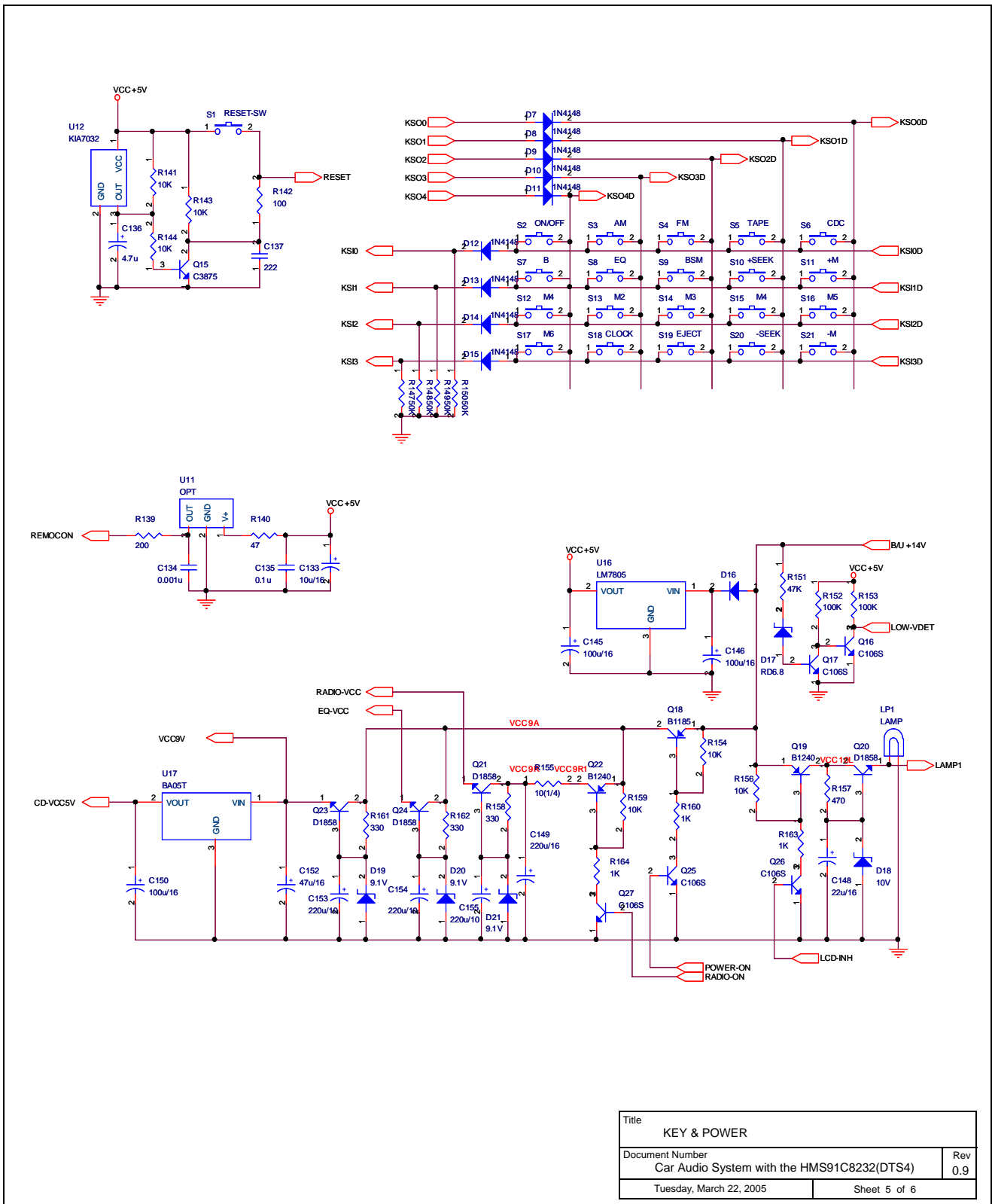

Figure 6. AMP of Car Audio System



Title		KEY & POWER
Document Number		Car Audio System with the HMS91C8232(DTS4)
Tuesday, March 22, 2005		Rev 0.9
Sheet 5 of 6		

Figure 7. KEY of Car Audio System

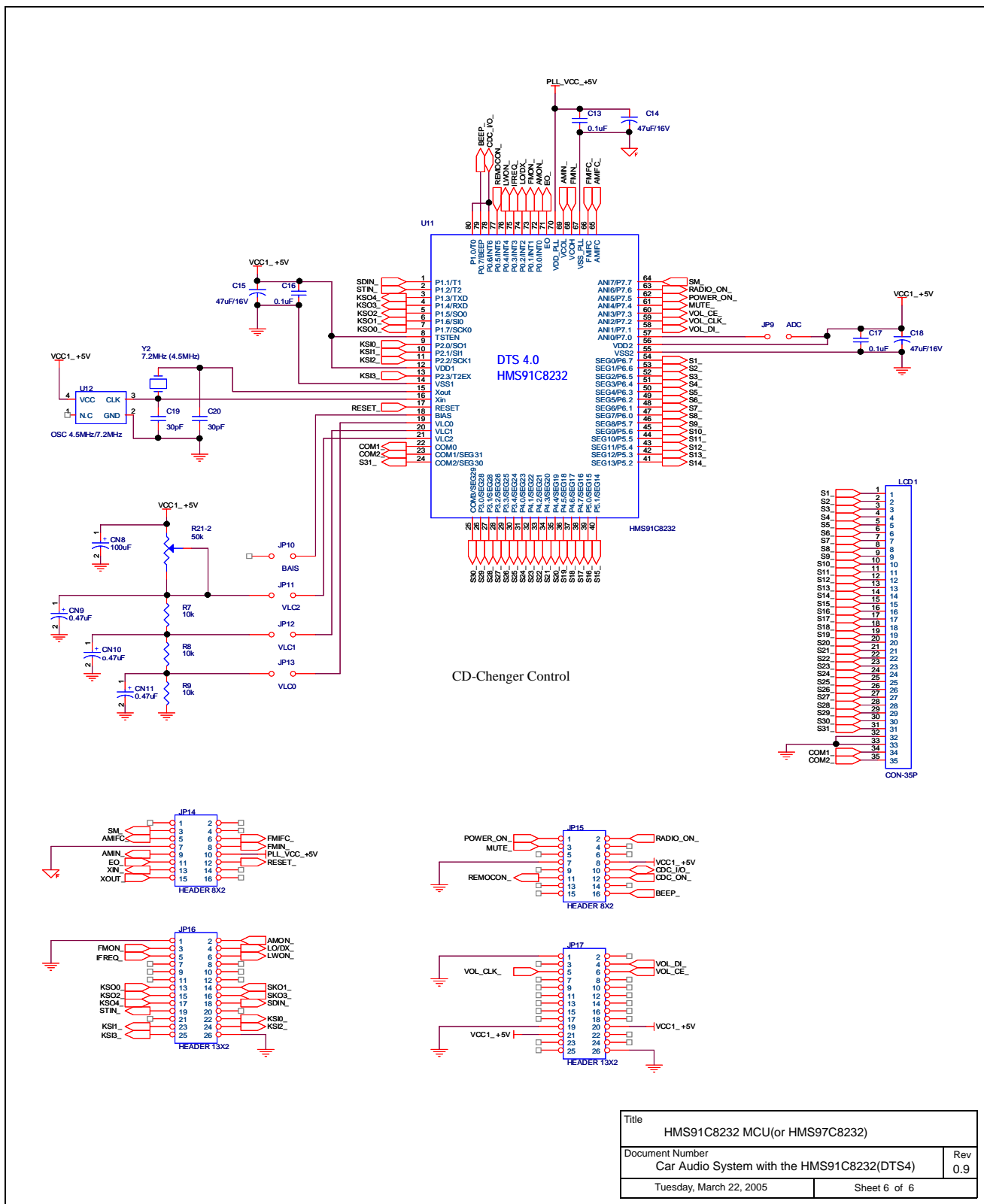

Figure 8. MCU of Car Audio System